

509-51075

IKM Technology AS

**Subsea Saw 70-250mm User Manual
IKM-1077988**

01	-	23.04.2020	Issued for Review	OG	BØ	EN	
Rev.	Client Rev.	Issue Date	Description	Prepared by	Checked by	Approved by	
			Document Title: Subsea Saw 70-250mm User Manual IKM-1077988				
 IKM Technology AS			System: NA	Area: NA	TAG: NA		
			Document No.: 509-51075-IKM-U-MA-001				Rev.: 01
			Client Document No.: NA				Client Rev.: NA
			<i>Note: Where not applicable use NA</i>				Total No. of Pages: 15
Contract No.:	CTR No.:	Project Code	Originator Code	Discipline Code	Document Code	Sequence Number	
	NA						

Project:	509-51075	Date:	19/06/2020
Document Title:	Subsea Saw 70-250 mm User Manual	Page:	2 of 15
Document No.:	509-51075-IKM-U-MA-001	Rev.	01
Client Doc. No.:	NA	Rev.	NA

Table of Contents

1	General Information	3
1.1	Abbreviations	3
1.2	References	3
1.3	Document Revision Sheet	4
2	Technical Specification.....	5
3	Technical Data	7
4	Safety	8
4.1	General - Operations	8
4.2	General - Hydraulic	8
4.3	General - Mechanical	9
5	Operational Description	10
5.1	Transportation	10
5.2	Preparation on the vessel prior to operations	11
5.3	Flow control valve/regulator	12
5.4	Subsea use	13
6	Maintenance	14
6.1	After operations	14
6.2	Periodic maintenance	14
7	Spare part list	15

Project:	509-51075	Date:	19/06/2020
Document Title:	Subsea Saw 70-250 mm User Manual	Page:	3 of 15
Document No.:	509-51075-IKM-U-MA-001	Rev.	01
Client Doc. No.:	NA	Rev.	NA

1 General Information

This manual is a user manual for the Subsea Saw Ø70-250mm cutter tool.

The Subsea Saw has a rotating blade which can be up to 700 mm in diameter. It is built to be operated by ROV and controlled with the ROV manipulator. To drive the Subsea Saw hydraulic power is supplied from the ROV.

It is designed to cut steel pipes/profiles, wires and flexible risers. The Subsea Saw is usually equipped with a carbide or a diamond saw blade. The Subsea Saw is equipped with claws to hold on to the object being cut. The claws can be modified to the specific interface being cut on request.

1.1 Abbreviations

The following abbreviations are used throughout the document:

Table 1-1 Table of Abbreviations

Abbreviation	Explanation
ROV	Remotely Operated Vehicle
OD	Outer Diameter
COG	Center Of Gravity
CCM	Cubic centimetre
LPM	Liters per minute
Nm	Newton meter
CW	Clockwise
RPM	Rounds per minute
CCW	Counter clockwise

1.2 References

Table 1-2 Table of References

Document No.	Document Title	Rev.	Issued	Can be found
IKM-1077624	Subsea Saw 70-250mm	02	16.03.2020	IKM Technology server

IKM Technology AS

Project:	509-51075	Date:	19/06/2020
Document Title:	Subsea Saw 70-250 mm User Manual	Page:	4 of 15
Document No.:	509-51075-IKM-U-MA-001	Rev.	01
Client Doc. No.:	NA	Rev.	NA

1.3 Document Revision Sheet

Table 1-3 Table of Revision Changes

Document Revision Sheet		
Revision	Date	Notes
01	23.04.2020	First revision

2 Technical Specification

The Subsea Saw main components is; saw frame, , feed cylinder, hydraulic motor, cutting blade, claws, claw cylinders and Char-Lynn 2000 series motor (306ccm).

Hydraulic supply and control of the Subsea Saw is by means of and through the ROV system, or by use of deck HPU for surface cutting.

Recommended cutting diameter is set to Ø70-250 mm.

Hydraulic system main parts:

Motor: CHAR-Lynn 2000 serie, 306 ccm - IKM-1048754

Valve block (IKM Technology): 7146-121

Flow control valve/regulator: 672878 QV-06/1 - IKM-1047833

Pressure relief valve: SVC56C - IKM-1048753

Check valve: FT2260/6-12 - IKM-1057506

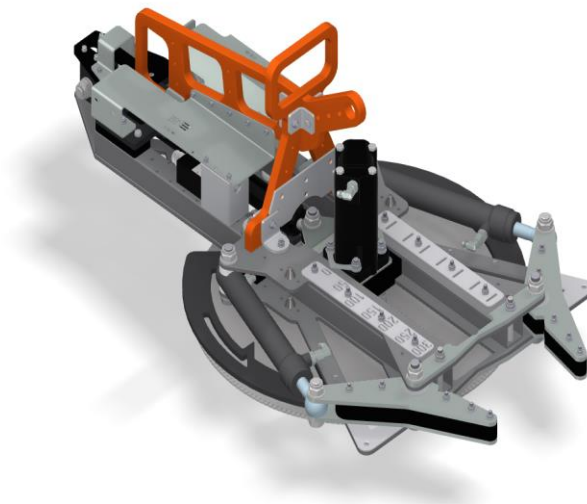

Figure 2-1 Subsea Saw, ISO VIEW

IKM Technology AS

Project:	509-51075	Date:	19/06/2020
Document Title:	Subsea Saw 70-250 mm User Manual	Page:	6 of 15
Document No.:	509-51075-IKM-U-MA-001	Rev.	01
Client Doc. No.:	NA	Rev.	NA

IKM Technology AS

Project:	509-51075	Date:	19/06/2020
Document Title:	Subsea Saw 70-250 mm User Manual	Page:	7 of 15
Document No.:	509-51075-IKM-U-MA-001	Rev.	01
Client Doc. No.:	NA	Rev.	NA

3 Technical Data

Table 3-1 Technical Data Table - Subsea Saw 17-250mm

Description General	Description Detailed		Value	Unit
Dimensions	Complete Arrangement	L x W x H	1198 x 735 x 481	mm
	Cutting diameter	Min / max	Ø17 / Ø250	mm
	Saw blade	Typical	Ø60 / Ø700	mm
Weight	Complete Arrangement	In air	67 + blade	kg
		In water	50 + blade	kg
Hydraulics	Pressure, flow and connections	Motor	165-207	Bar
			>45	LPM
			¾ JIC	Inch
		Feed cylinder	Feeds of motor function	Bar
			Feeds of motor function	LPM
			NA	Inch
		Claw cylinders	150-207	Bar
			<15	LPM
			7/16 JIC	Inch

Note: The dimensions are when the Subsea Saw is equipped with up to Ø700mm saw blade.

Project:	509-51075	Date:	19/06/2020
Document Title:	Subsea Saw 70-250 mm User Manual	Page:	8 of 15
Document No.:	509-51075-IKM-U-MA-001	Rev.	01
Client Doc. No.:	NA	Rev.	NA

4 Safety

4.1 General - Operations

Only authorised people and qualified personnel should work on the system, and take suitable precautions to prevent any potential injuries. Always adhere to authorised working practices, and use the correct tools for the job. To facilitate this, make sure that these are available before commencing a test of the tool.

Ensure that the working area is kept clear and uncluttered.

WARNING !!



The tool is fitted with a potentially very dangerous and extremely sharp saw blade with real cutting hazard also when not rotating.

Wear proper PPE for manual handling of the blades, and minimum 2 persons should handle the blade.

During hydraulic operation/testing of the tool; establish barriers around work area and never operate the blade rotation before personnel are confirmed to be in a safe distance from the tool.

4.2 General - Hydraulic

Do not work on pressurised systems. Hydraulic systems contain a large amount of stored energy when pressurised, therefore the system (including any accumulators) should be de-pressurised, and the power pack switched off, prior to working on the system. Exceptions to this would be system adjustments to components requiring the presence of pressure and/or flow.

Any personnel authorised to work on the system must have a complete understanding of the operation of the hydraulic system, so that they will be aware of any system liable to remain pressurised or hazardous in any other way. Ensure that all personnel are clear of any mechanical/hydraulic system likely to move if pressure to system actuators is released or applied.

Do not attempt to tighten any leaking fittings whilst under pressure. A hose/fitting rupture could result, leading to injury from flying components and/or oil jets.

Regularly inspect fittings and pipe-work for mechanical damage. If any such damage is found, the item must be repaired or replaced as necessary before pressure is applied to the system. Do not allow damaged fittings to remain in service.

IKM Technology AS

Project:	509-51075	Date:	19/06/2020
Document Title:	Subsea Saw 70-250 mm User Manual	Page:	9 of 15
Document No.:	509-51075-IKM-U-MA-001	Rev.	01
Client Doc. No.:	NA	Rev.	NA

Take care when inspecting, commissioning, repairing or maintaining the system to avoid jets of oil issuing from open orifices; pipe ends etc. if pressure is applied. Particular care should be taken to protect the eyes.

Hydraulic components may be heavy and slippery when covered in oil. Ensure that adequate protective clothing and footwear is used.

Any moving component should be treated with caution when the system is pressurised during operation, and especially during on-deck testing and repair. Keep clear of all moving components, and take all necessary precautions to avoid injury when working on these systems by preventing movement of any components likely to cause injury.

4.3 General - Mechanical

Beware of and keep clear of all moving components. Do not work on the system whilst power is applied, or if there is any potential for components to move.

Ensure that all load bearing components are adequately and regularly inspected. If damage is found the component must be repaired/replaced as necessary. Do not allow damaged components to remain in service.

Always ensure that items are correctly and adequately supported before removal, and that authorised lifting equipment and procedures are used.

Note: trying to lift heavy components in an awkward position by hand without the assistance of correct lifting equipment, or lifting any component without adopting the correct stance, can lead to serious injury.

Ensure that when working within or underneath the machine that your presence is known to your supervisor. If working underneath the machine, always ensure that there are no loose or unsupported assemblies, components or tools above.

5 Operational Description

The following description is a general description of preparation and use of the Subsea Saw 170-400/425mm. Customers are advised to adapt the following information to their own specific operations and specific work area.

5.1 Transportation

Make sure that the saw is properly strapped in the transport box, example of how to do this is shown in the picture below:



Figure 5-1 Transport

WARNING !!



The tool is fitted with a potentially very dangerous and extremely sharp saw blade with real cutting hazard also when not rotating.

Project:	509-51075	Date:	19/06/2020
Document Title:	Subsea Saw 70-250 mm User Manual	Page:	11 of 15
Document No.:	509-51075-IKM-U-MA-001	Rev.	01
Client Doc. No.:	NA	Rev.	NA

Wear proper PPE for manual handling of the blades, and minimum 2 persons should handle the blade.

During hydraulic operation/testing of the tool; establish barriers around work area and never operate the blade rotation before personnel are confirmed to be in a safe distance from the tool.

5.2 Preparation on the vessel prior to operations

- Unpack all parts and check for transport damages
- Verify that all parts on equipment list is present
- Always use the orange painted handles for lifting and handling of the subsea saw.
- **DO NOT** rest subsea saw weight/loads on saw blade or on motor hub and shaft. Use tree trunks or similar between floor/deck and saw framework to carry the tool loads.
- Check all hoses and fittings for damage and leaks.
- Check that all bolts are in place and tight.
- Connect the hydraulic hoses to the ROV corresponding hydraulic system.
- Ensure that the piston on the feed cylinder is fully retracted.
- **After function and feed rate test:** Check the cutting blade for damage and install it on the subsea saw.
- **After function and feed rate test:** Check that the blade is installed correctly, not loose and correct direction.
- **Secure Subsea saw in ROV manipulator(s) or clamp it on suitable “dummy-stand”, and ensure personnel is safe distance from the tool before rotating the blade.**
- **With a secured tool:** Rotate blade to full RPM to verify no excessive vibrations or misalignment of blade installation.

Function test:

- Do not start the saw on deck without securing the area.
- Run the clamp cylinders to full stroke.
- Time the motor feed rate - preferably WITHOUT the blade installed. Feed rate will be adjusted as part of the mobilization and should as such not be required to adjust on site. (Typical feed rate will be 15-25mm/min). However, should adjustment be required, follow the description below;
- If the motor feed rate is too fast/slow, adjust it using the feed flow regulator and try again. (This is also dependent on the ROV flow and pressure).

5.3 Flow control valve/regulator

Adjust flow wheel:

Locking wheel:

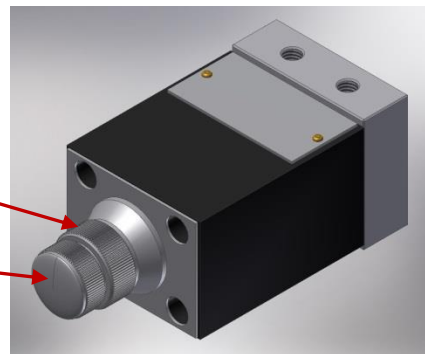

Figure 5-2 Flow control valve

- The regulator is located on the right hand side (looking at the saw from behind).
- The regulator can be adjusted to change the feed rate.
- Start by loosening the locking wheel CCW while holding the adjustment flow wheel from turning.
- Adjust the flow wheel in small increments.
- When desired feed rate is confirmed; tighten the locking wheel.

Project:	509-51075	Date:	19/06/2020
Document Title:	Subsea Saw 70-250 mm User Manual	Page:	13 of 15
Document No.:	509-51075-IKM-U-MA-001	Rev.	01
Client Doc. No.:	NA	Rev.	NA

5.4 Subsea use

- Ensure that all the checks in the preparations section have been performed.
- Ensure that the saw is securely fastened to the ROV using the designated ROV handles.
- Alternatively, the saw can be operated via Hot Stab system and deployed to working depth by means of a subsea basket or by user of crane.
- If deployed in basket; ensure tool weight/loads are carried by tree trunks or similar against tool framework, and NOT resting against saw blade/hydraulic motor shaft/hub. Secure tool for deployment through splash zone. (Heavy duty strips, ropes or similar).
- Engage the saw into cutting position.
- Activate the clamp cylinders to lock the Subsea Saw to the object to be cut, (ensure it is securely fastened). Always leave clamp-close function activated during cutting.
- Release manipulator hold/grip on the saw and confirm that saw is secured to the cutting object by the claws. (Do NOT perform cutting with tool secured in manipulator grip).
- Start spinning the saw blade at full speed. Operating the rotation of the blade will also cause the feed cylinder to activate.
- Observe the saw closely during cutting. Pay particular attention to excessive movements and/or vibrations, and blade rotation speed. Excessive movements/vibrations or substantial decreasing rotation speed can indicate too high setting of the feed rate. Reduced rotation speed can also be caused by restriction/limitations in the hydraulic supply. (Confirm/verify ROV check valves and stab systems if they are in use - ensure that minimum recommended flow for the motor is actually supplied).
- Perform the cut to complete separation of the cut object.
- When the cut is finished, retract the saw blade. This is done by reversing saw blade rotation valve/function.
- Secure Subsea Saw in ROV manipulator. Ensure safe grip before releasing clamp function.
- Open the clamp cylinders.
- Return to deck and perform "After operations maintenance".

Project:	509-51075	Date:	19/06/2020
Document Title:	Subsea Saw 70-250 mm User Manual	Page:	14 of 15
Document No.:	509-51075-IKM-U-MA-001	Rev.	01
Client Doc. No.:	NA	Rev.	NA

6 Maintenance

Only qualified personnel, preferably trained on this equipment, shall perform repair and maintenance work on the saw.

6.1 After operations

- Always use the orange painted handles for lifting and handling of the subsea saw.
- **DO NOT** rest subsea saw weight/loads on saw blade or on motor hub and shaft. Use tree trunks or similar between floor/deck and saw framework to carry the tool loads.
- Clean the tool with fresh water. Apply an anti-corrosive layer on the tool when it is clean; WD40 or similar.
- Check hydraulic hoses, pipes, fittings and bolts, etc.
- Check the saw blade for damage. Replace if damaged or worn-down teeth.
- Remove saw blade before storing in transport/storage box.
- When stored; make sure the clamp and feed cylinders are fully retracted, to avoid corrosion.
- Plug hydraulic hoses to prevent hydraulic leaks and dirt to enter the hydraulic system.
- Place tool in its original transport case/storage box and secure with straps.

6.2 Periodic maintenance

- Start with “After operations” maintenance procedure.
- A careful review of the entire tool is mandatory. This includes a visual check of the tool with hoses and a function test. Be sure that there is no leaks and that the feeding rate is correct.
- Replace or fix parts if needed. Apply touch-up paint as required.

IKM Technology AS

Project:	509-51075	Date:	19/06/2020
Document Title:	Subsea Saw 70-250 mm User Manual	Page:	15 of 15
Document No.:	509-51075-IKM-U-MA-001	Rev.	01
Client Doc. No.:	NA	Rev.	NA

7 Spare part list

- Cutting blade
- Flow adjust valve, (Feed control valve)
- Main hydraulic motor
- Saw blade hub
- Saw blade locking plate w. bolts
- Claw cylinder(s)
- Claw