

SUBSEA SAW 70 – 250 MM

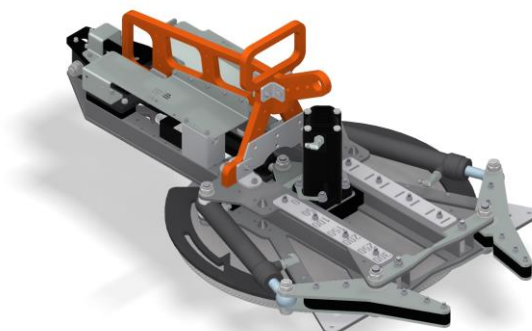

The IKM Subsea manipulator held **Subsea Saw** has a long track record. It is designed to cut steel pipes, profiles, chains, armored cables and flexible riser up to 250 mm. The saw has a clamp and an automatic feed function on the sawblade.

SPECIFICATIONS

Type	Subsea Saw
Model	70 – 250 mm
Part number	IKM-1077988
Dimensions LxWxH	1362 x 734 x 481 mm
Cutting diameter	Ø70 – Ø250
Saw blade	Ø600 (Ø700)
Motor	305 cc
Recommended feed rate	15-25 mm/min
Hydraulic Connections	2x ½" BSP (HF) 2x ¼" BSP (LF)
Hydraulic pressure	180-200 bar
Hydraulic flow	55-65 LPM
Weight in air	85 kg
Weight in water	60 kg
Number of hydraulic connections	4 hoses (two functions) HF: Minimum NG6 Valve LF: NG4 or NG3 Valve

- Clamps can be modified for different interfaces and diameters if required.
- Standard blades supplied with the saw are Ø600 carbide type.
- HF: Minimum NG6 Valve
- LF: NG4 or NG3 Valve